



List 8333

A BRAND AE-VTSS



NEW

SPEED FEED
1345-1346

CARBIDE

DUARISE

3 FLUTE

40-43°



SHRINK FIT

STUB

PACKED
1 PIECE

Cutting Diameter Tolerance	
3mm ≤ D ≤ 12mm	+0 / -0.020mm

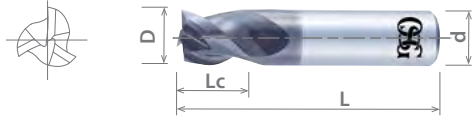

EDP Number		Diameter		Length of Cut		Neck Length		Non-Taper Neck Length		Overall Length		Shank Diameter		Type
		D (mm)	Lc (mm)	L1 (mm)	L2 (mm)	L (mm)	d (mm)	d (mm)						
8557251	●	3.00	4.50	12.20	6.00	45.00	6.00	1						
8557252	●	4.00	6.00	11.90	7.00	45.00	6.00	1						
8557253	●	5.00	6.00	11.70	9.00	45.00	6.00	1						
8557254	●	6.00	6.00	-	-	45.00	6.00	2						
8557255	●	8.00	8.00	-	-	45.00	8.00	2						
8557256	●	10.00	10.00	-	-	45.00	10.00	2						
8557257	●	12.00	12.00	-	-	50.00	10.00	3						

● Stocked ○ Available Upon Request; MOQ May Apply ▲ Globally Stocked

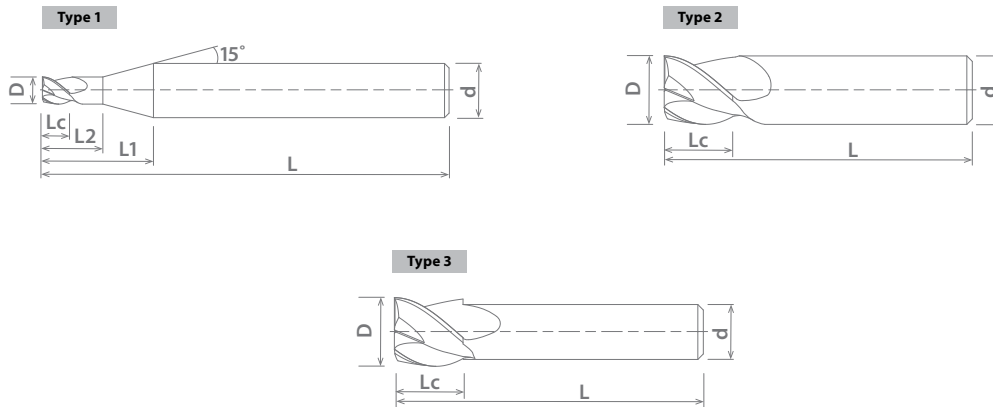

P					M			K	N		S		H			
Steel					Stainless Steel			Cast Iron	Non-Ferrous		HRSA		Hardened Steel			
Carbon Steel			Alloy Steel	Die Steel	Aluminum		Nickel Alloy		Titanium	Hardened Steel						
Low	Medium	High			6061	7075				Casting	Inconel	6Al4V (30 HRC)	~35 HRC	35-45 HRC	45-50 HRC	50-70 HRC
1010	1035	1065	4140	4340	300	400	17-4 PH	6061	7075	Casting	Inconel	6Al4V (30 HRC)	~35 HRC	35-45 HRC	45-50 HRC	50-70 HRC
○	○	○	○	○	○	○	○	○	○	○	○	○	○	○	○	○

○ Good ○ Best

